

# T-0.1

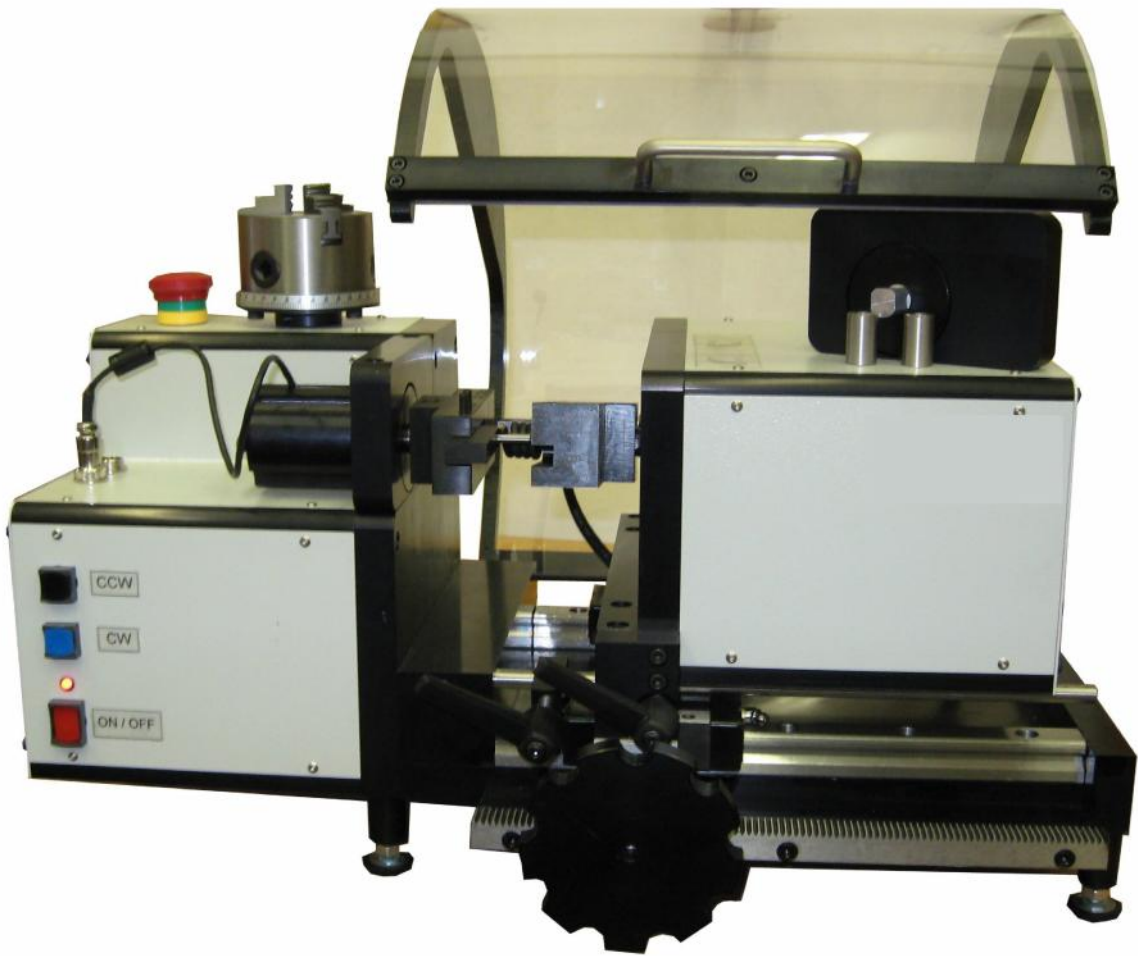

# Specifications

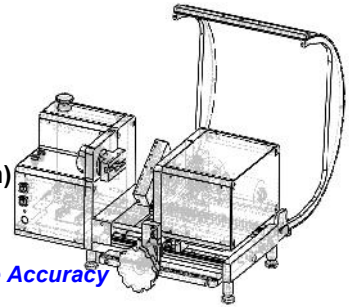
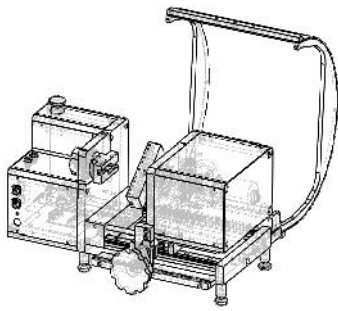

- Torque Capacity 0.100 NM (0.88lbf-in)
- Torque Resolution 0.00001NM (0.00009lbf-in)
- Torque Accuracy  $\pm 0.00004$ NM ( $\pm 0.00036$ lbf-in)
- **Secondary Load Cell Possibilities:**

Torque Cell Type	Torque Capacity		Torque Resolution		Torque Accuracy	
	NM	Lbf.in	NM	Lbf.in	$\pm$ NM	$\pm$ lbf.in
0.010	0.01	0.088	0.000001	0.000009	0.000004	0.000036

## Torque

- Continuous digital display or Torque/Angle graphical analysis tools and display
- Interchangeable torque cells
- Safe overload to 200% of FS (Software overload protection at FS). Maximum torsion arm load of 500N (112lbf) with 20Nm load cell

## Angular Rotation

- Resolution: 0.01°
- Accuracy:  $\pm 0.1^\circ$
- Absolute display of angle from 0 - 50000°. Angle zeroed anywhere in this range. Test angle absolute or from free position.

## Fixtures

- Testing fixture with 4 pin hole sizes (for torque up to 20Nm) or optional 75mm (3.0") 3 jaw chuck (for torque up to 2Nm)

## Body Length OD

- 152mm (6") Maximum
- 80mm (3.2") Maximum

## Computer

- 2.4GHz (minimum) Dual Core processor
- USB port for PC data transfer
- Fully Microsoft Windows 2000, XP, Vista and Win 7 compatible)
- 17" SVGA Color monitor supplied with PC

## Languages

- English, German, Turkish

## Software Features

- Active Torquecell Electronically Identified
- Programmable for automated testing, including spring rate results.
- Full reporting and printing capability available.
- SPC control charts available.
- Smart self calibration routines
- Automatic or manual determination of torsion rate (linear analysis)
- Nm, Nmm, kgf-m, gf-mm, kgf-cm, ozf-in, lbf-in and angles in degrees or revolutions

## Units

## Test speeds

- 0 – 6 RPM, servo motion controlled

## Dimensions

- 520mm x 228mm x 224mm (20.5"x9"x8.8") – LxBxH
- Weight 20kg (50lbs)

## Power

- 110V~220V AC 1.5A (Maximum)



[WWW.SASTESTERS.COM](http://WWW.SASTESTERS.COM)

Ph: +972-9-7603895

Fax: +972-9-7604849

E-Mail: [Info@SASTESTERS.COM](mailto:Info@SASTESTERS.COM)